

Dimensional Drawing

REVISIONS					
Rev	Description	Designed	Reviewed	Approved	Date
01	Created	KHM	KTN	KTN	2026-05-05

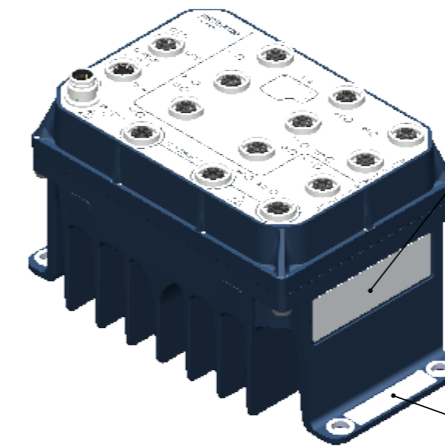
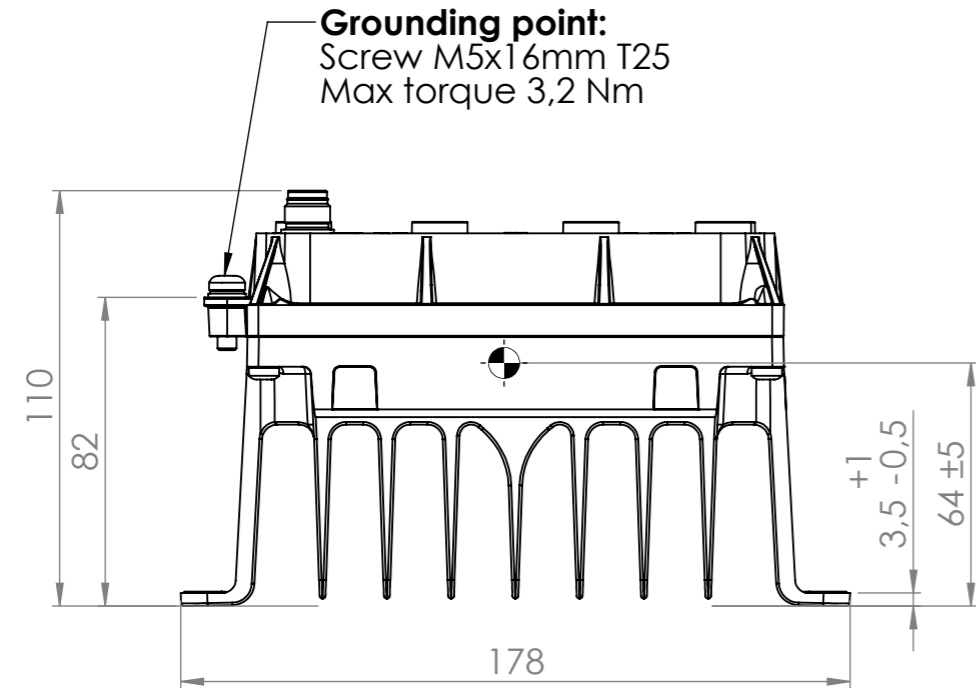

Label:
Part number (P/N)
Type
Power
MAC
Serial number (S/N)
2D-datamatrix (P/N, MAC, S/N)

Label:
Type
Part number (P/N)
Serial number (S/N)
2D-datamatrix (P/N, MAC, S/N)

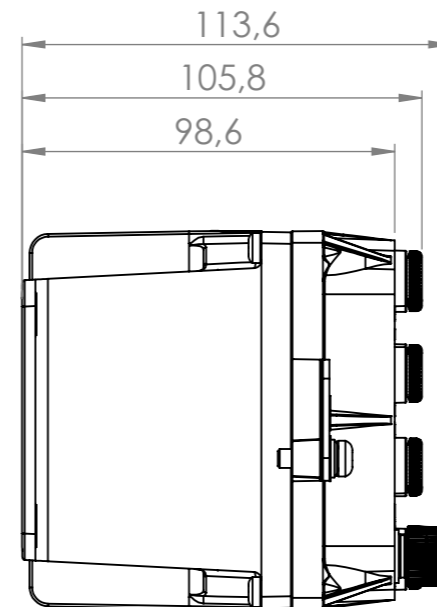
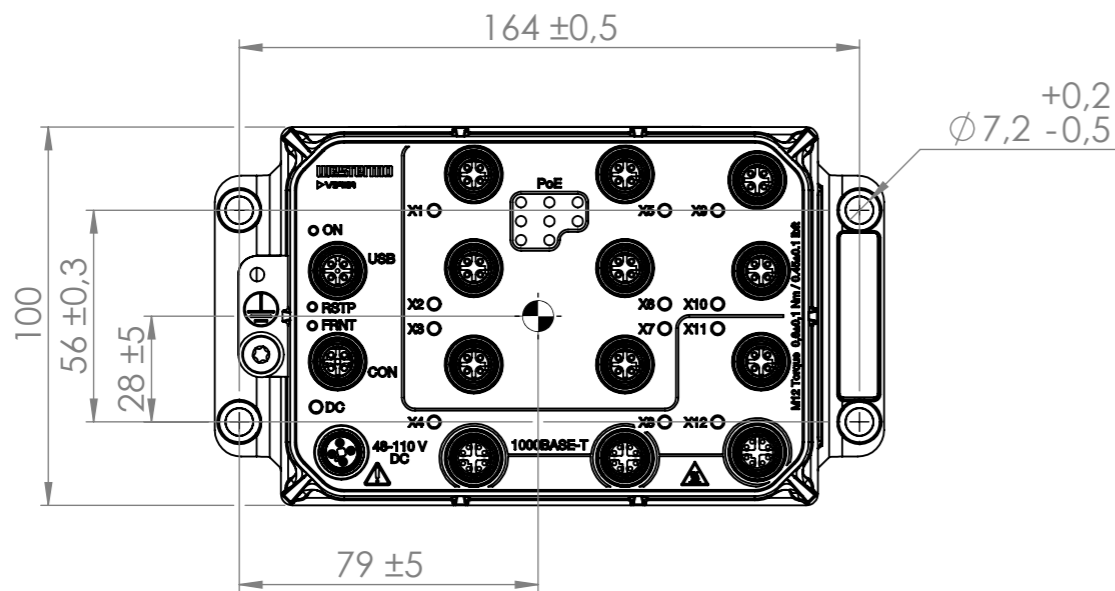

With protective caps on ports

Weight: 1555 ±20 g

Product list	
Part Number	Type
3635-0430	Viper-3512-T3G-T1-P8-HV-PPC
3635-0440	Viper-3512-E-T3G-T1-P8-HV-PPC

	Denomination Viper-3512-T3G-T1-P8-HV-PPC-BASE	Tolerance ±2 mm		Designer KHM	Approved KTN	Date 2026-05-06	Scale 1:2	Sheet 1(1)
		Drawing No. 5100-0101-UD-01			Status Approved			