

Dimensional Drawing

REVISIONS					
Rev	Description	Designed	Reviewed	Approved	Date
01	Created	KHM	KTN	KTN	2026-05-05

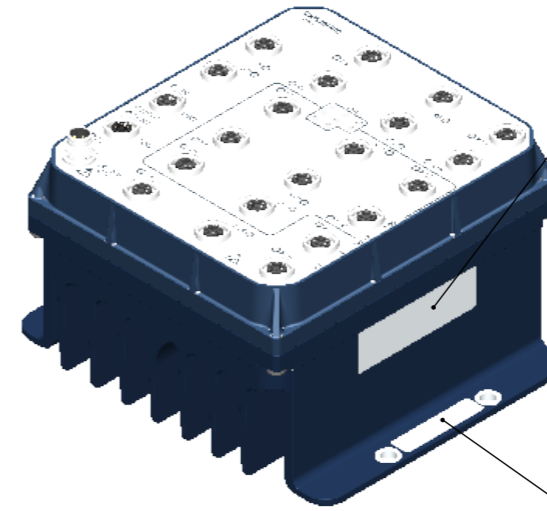
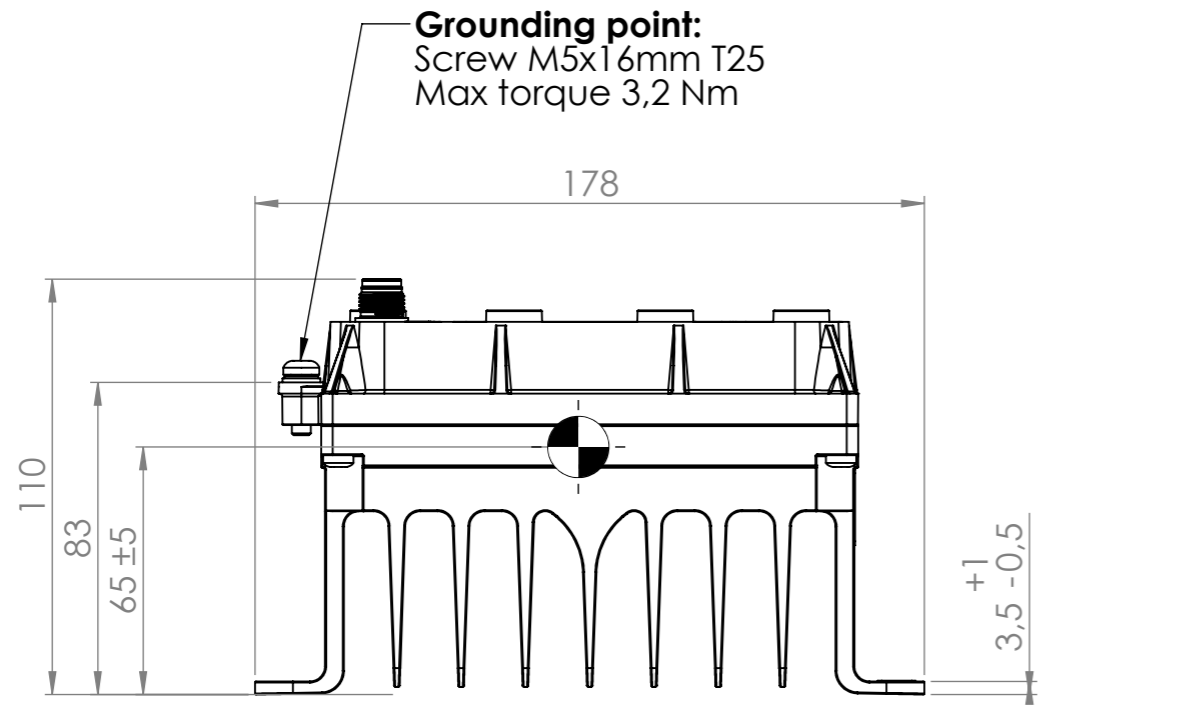

Label:
 Part number (P/N)
 Type
 Power
 MAC
 Serial number (S/N)
 2D-datamatrix (P/N, MAC, S/N)

Label:
 Type
 Part number (P/N)
 Serial number (S/N)
 2D-datamatrix (P/N, MAC, S/N)

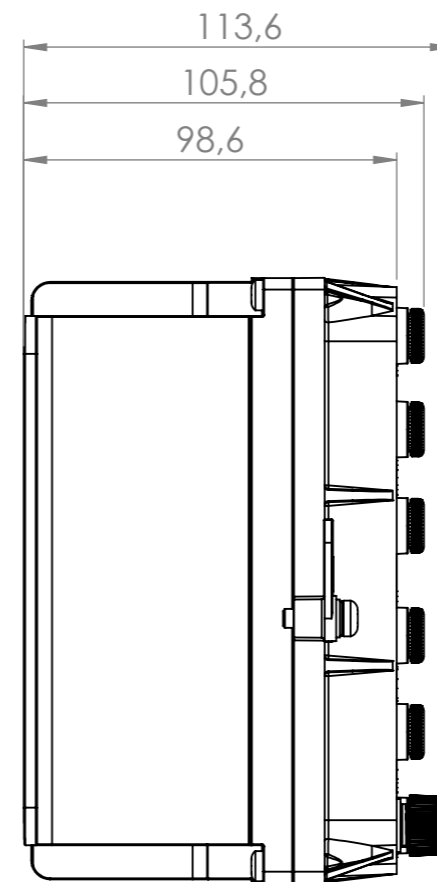
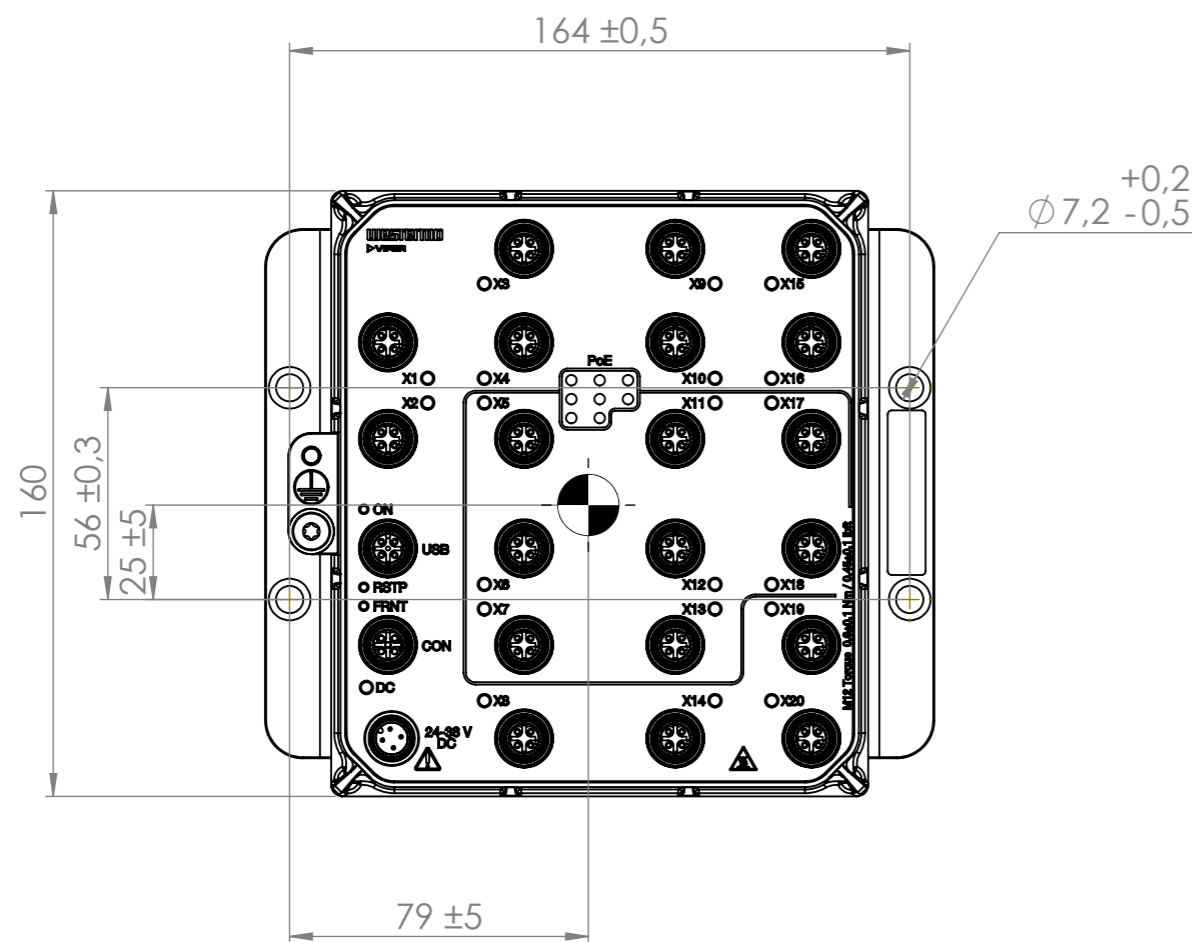

With protective caps on ports

Weight: 2324 ± 20 g

Product list	
Part Number	Type
3635-1130	Viper-3520-T12-P8-LV-PPC
3635-1140	Viper-3520-E-T12-P8-LV-PPC

	Denomination Viper-3520-T12-P8-LV-PPC-BASE	Tolerance ± 2 mm		Designer KHM	Approved KTN	Date 2026-05-06	Scale 1:2	Sheet 1(1)
		Drawing No. 5100-0102-UD-01			Status Approved			